

TWIN AUGER VERTICAL MIXER « VD »



- Towed vertical mixer
- Two augers with cutting blades
- 4 weighing cells diam. 54 mm over independent frame
- Side unloading door
- 4 mechanical counter knives
- Single ladder
- Two speed gear box
- Direct operation by tractor hydraulics
- Non programmable scale
- Hydraulic foot
- Height adjustable Drawbar
- Single PTO shaft
- Single wheels

Type 445/45. 19,5



TATOMAX[®]
GRUPO

« VD » TWIN AUGER VERTICAL MIXER TECHNICAL SPECIFICATIONS

	VOLUME m ³	POWER HP	TYRES	A mm.	Bmm.	Cmm.	Dmm.	Emm.	F mm.	Tare Kgr.
VD 175	17	85	445/45-19,5	6205	3717	2428	1942	2729	680	5450
VD 205	21	95	445/45-19,5	6271	3717	2548	1942	2941	680	5885

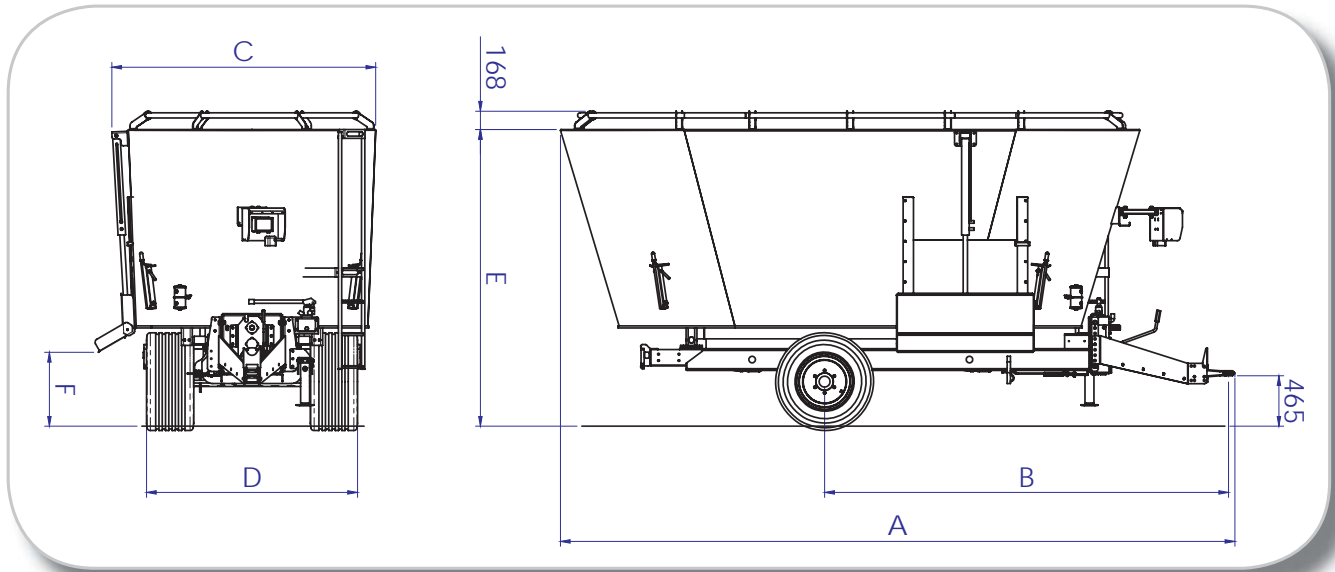

TATOMA[®]

GRUPO

**INGENIERÍA Y MONTAJES MONZÓN, S.L.
(INMOSA)**

Polígono Industrial PAULES 53-55
22400 Monzón (Huesca) ESPAÑA

Tel: (+34) 974 401 336
FAX: (+34) 974 400 670

inmosa@grupotatoma.com
www.grupotatoma.com

OPTIONS ON « VD » VERSION

CODE	DESCRIPTION
V001218	2nd Side door
V001900	Anti-overflow ring "VD" range
V001932	Solid anti-overflow ring (BOLTED)
V005501	Programmable weighing system
V002006	2 Hydraulic counter-knives
V002007	4 Hydraulic counter-knives
5501	Programmable scale perin M-700
V001245	Hydraulic rising elevator on side door 930mm (on steel)
V001246	Hydraulic rising elevator on side door 930mm (on stainless steel)
V001202	Elevator extensión 0,3 mts (1230 mm)
V001203	Elevator extensión 0,5 mts (1430 mm)
V001206	Elevator bottom, chain and crossbeams made on stainless steel(930 mm)
V001207	Elevator bottom, chain and crossbeams made on stainless steel (1230 mm)
V001208	Elevator bottom, chain and crossbeams made on stainless steel (1430 mm)
V001403	Wide angle CV PTO
V001403	Wide angle CV PTO shaft
V002100	Double Wide angle CV PTO shaft
V002701	Magnet plate
V001303	Battery Kit