

SELF-PROPELLED VERTICAL DOUBLE AUGER MIXER

“DUPLOMIX” MVS



TATOMA
SHAPI

SELF-PROPELLED VERTICAL DOUBLE AUGER MIXER

“DUPLOMIX” MVS

The self-propelled MVS “ DUPLOMIX” mixer perfectly balances efficiency and ease of use. This machine is designed for the medium sized herd and provides excellent manoeuvrability which can be enhanced with the 4-wheel drive option. The main functions of the machine are controlled from the cabin by means of “joystick” enabling greater precision especially when using the front cutter for loading jobs. Cabin design assures maximum visibility thanks to a large windowed surface area.



The mixer is fitted with leafspring front suspension as standard that ensures maximum operator comfort on rough terrain, leaf spring suspension can also be fitted on the rear axle as an option.



Optional hydraulic suspension



Dual augers



cutter system

The cutter system is designed to ensure maximum speed and efficiency in order to reduce the loading time and optimize the quality of work without damaging the product thereby reducing production costs.



standard equipment

- Mixing system with dual vertical heavy duty augers and replaceable knives.
- Engine situated on the front right-hand side (IVECO 175 CV).
- Hydraulic circuit situated behind the cab with flexible piping.
- Springleaf front suspension.
- Rubber loading belt.
- Front-axle drive and steering.
- Parking, service and emergency brake on the front axle.
- Driving speed 0- 15 km/h(25 km/h Option).
- Front directional axle allows 40° turning.
- Variable flow pumps to drive the movement and the heavy duty mixer series.
- Heavy duty piston mixer motor (420 bar).
- Steel bottom and sides ST52.
- Steel auger ST52.
- 2000 mm long cutter with 60 CV motor.
- Fold back cabin door.
- Seat with pneumatic suspension.
- Programmable scale.
- Cutter lowering adjustment manually driven from the cabin.
- Pressure switch to adjust working pressure of the cutter.
- Mixer work pressure gauge indicator.
- Mixer gear oil temperature indicator.
- Hydraulic oil temperature indicator.
- Low hydraulic oil level gauge.
- Breakdown lights.
- Fire extinguisher.
- Working lights.



Large glass panels ensures maximum all-round visibility even through the top of the cabin, ensuring perfect control during the cutting operation.

175 CV 6-cylinder IVECO high performance Engine 175 hp mounted so as to allow perfect cooling. The reversible fan option makes it easy to clean any dust while working. The housing is designed for easy access during maintenance tasks



Cutter rotation control



cabine

The cabin front is designed to slope inwards, preventing dust generated during the cutting operation settling and obliterating operator visibility.



A multi-function joystick is used to provide most of the control operations of the mixer providing accurate, agile handling of the machine.

* Data and descriptions are for information purpose only. TATOMA reserves the right to modify the design or specifications with no prior notice.

general features



SIDE-DOOR UNLOADING



WORKING LIGHTS
Optional LED Technology.

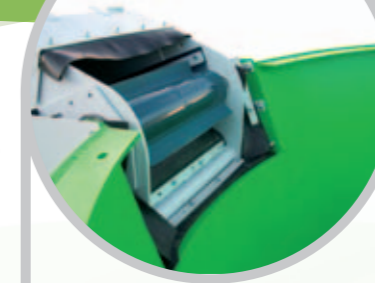

LOADING BELT
Rubber loading belt, optional polyethylene chain and crossbars.



REAR UNLOADING BELT
Optional moveable belt.



* STRAW CHOPPER ON REAR OPTION

MIRROR
Option heated mirrors, electrically adjustable and movable right mirror.



CABIN
Spacious cabin with maximum visibility. Foldable door for easy access.



IMPORTANT NOTE
All models are available either with side discharge door (mod.DL) or rear belt discharge (mod. DC).

TRACTION
Front axle drive and steering. Optional dual wheel drive and dual axle steering.

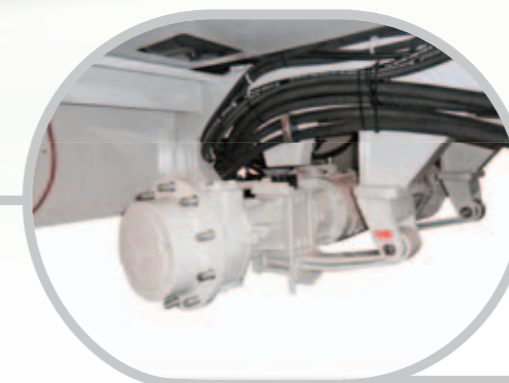

SUSPENSION
Springleaf suspension on the front axle, optional rear axle springleaf.



* MODEL "DUPLOMIX" MVS 17

drive

4 driveable wheel enables the direction of each axle to be selected separately or both axles simultaneously. This enhanced manoeuvrability ensures that the machine can do its job regardless of how complicated the access is. This option along with 4-wheel drive assures maximum efficiency when conditions so require.

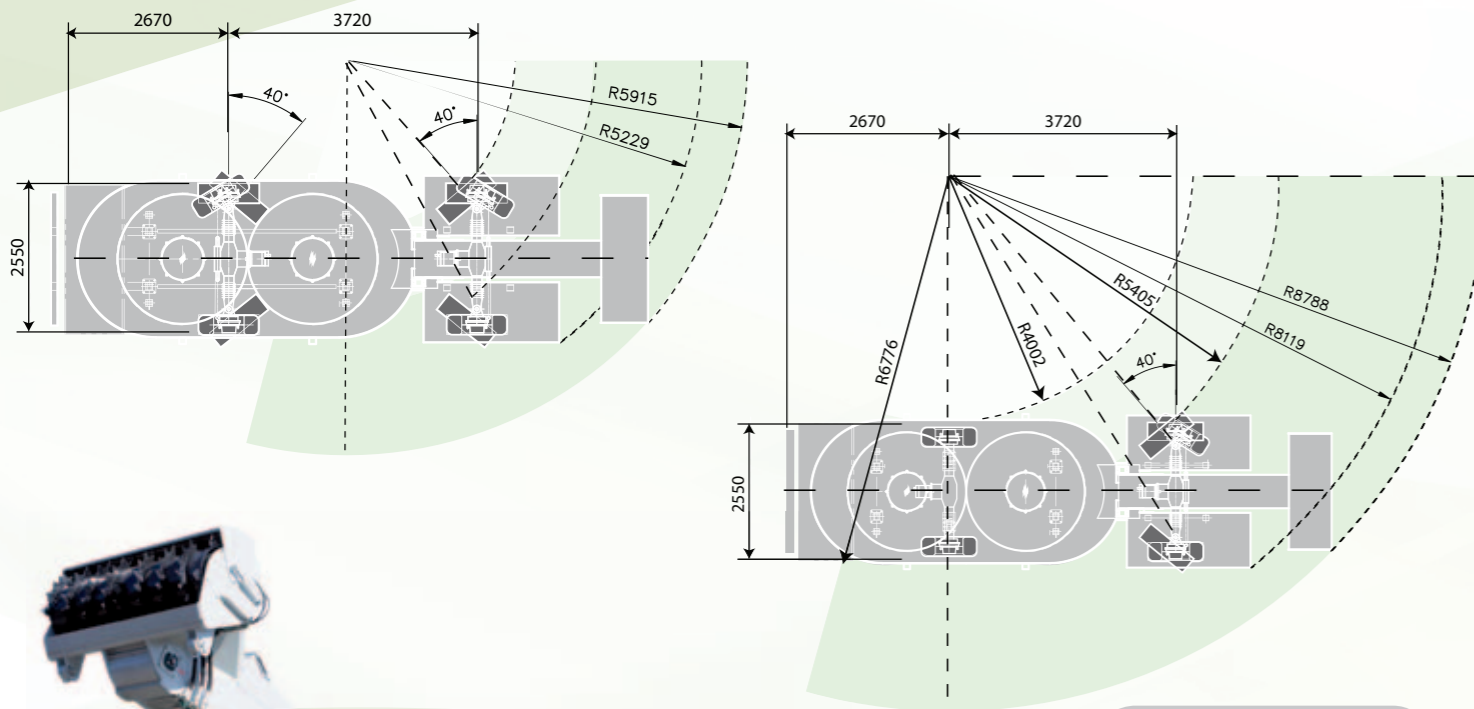

OPTION: CUTTER SUPPORT WITH HYDRAULIC CYLINDERS OR NITROGEN STORAGE CELL

optional equipment

OPTIONS	DL SIDE-DOOR UNLOADING				DC REAR UNLOADING BELT			
	MVS-145	MVS-160	MVS-17	MVS-19	MVS-145	MVS-160	MVS-17	MVS-19
Magnet (125 m³/h)	•	•	•	•	•	•	•	•
Air conditioned	•	•	•	•	•	•	•	•
Air conditioned + climatizer	•	•	•	•	•	•	•	•
Electrically heated rearview	•	•	•	•	•	•	•	•
Electrically heated and adjusted rearview	•	•	•	•	•	•	•	•
Sliding left rearview	•	•	•	•	•	•	•	•
Working light	•	•	•	•	•	•	•	•
LED Technologi working light	•	•	•	•	•	•	•	•
Documents and equipt to be register	•	•	•	•	•	•	•	•
Sweeper	•	•	•	•	•	•	•	•
Silo cutter support	•	•	•	•	•	•	•	•
Nitrogen suspension for the silocutter	•	•	•	•	•	•	•	•
175 HP reversible fan	•	•	•	•	•	•	•	•
238 HP reversible fan	•	•	•	•	•	•	•	•
Automatic greassing system	•	•	•	•	•	•	•	•
Manual greassing system	•	•	•	•	•	•	•	•
Bigger engine 175 to 238 HP IVECO	•	•	•	•	•	•	•	•
Front hydraulic suspension	•	•	•	•	•	•	•	•
TFT color 7"double video camera	•	•	•	•	•	•	•	•
Extreme temperature Kit (-20°C). Hydraulic oil heater and engine	•	•	•	•	•	•	•	•
Differential bloking (ONLY 4x4)	•	•	•	•	•	•	•	•
Two steering axle (4SW) 4 wheels 445/45-19,5 (ONLY MVS 17 and 19)	•	•	•	•	•	•	•	•
4 wheels drive (4WD) 4 wheels 445/45-19,5 (only MVS 17 and 19)	•	•	•	•	•	•	•	•
Two steering axle and 4 wheels drive (4WD x 4SD) 4 wheels 445/45-19,5 (ONLY MVS 17 and 19)	•	•	•	•	•	•	•	•
RADIO-CD Bluetooth phone	•	•	•	•	•	•	•	•
Back straw blower	•	•	•	•	•	•	•	•
2 Hydraulic restrictor knives	•	•	•	•	•	•	•	•
4 Hydraulic restrictor knives	•	•	•	•	•	•	•	•
With no silo cutter neither loading conveyor	•	•	•	•	•	•	•	•
Extra door in flat side (tray included)	•	•	•	•	•	•	•	•
Loading conveyor made on chain and poliethylene crossbeams	•	•	•	•	•	•	•	•
Sliding belt underneath the mixing tank	•	•	•	•	•	•	•	•
Sliding belt 250 mm each side or 500 mm one side	•	•	•	•	•	•	•	•
AISI 304 Stainless steel augers	•	•	•	•	•	•	•	•
Stainless steel silo cutter	•	•	•	•	•	•	•	•
Stainless steel mixing tank covering (1500 mm high)	•	•	•	•	•	•	•	•

• Option available
• Option not available



OPTION: FOLDAWAY SIDE LOADING BELT

OPTION: RETRACTABLE UNLOADING BELT



Programmable weighing system

TFT color 7"double video camera

Retaining shredders

Automatic centralized lubrication

“DUPLOMIX” MVS-DL SIDE-DOOR UNLOADING

DIMENSIONS (mm)	MVS-145	MVS-160	MVS-17	MVS-19
A OVERALL LENGTH	8790	8790	8600	8600
B DISTANCE BETWEEN AXLES	3131	3131	3720	3720
C MAXIMUM WIDTH	2550	2550	2550	2550
D OUTER WHEEL WIDTH	2330	2330	2330	2330
E OVERALL HEIGHT	2500	2650	3080	3250
F UNLOADING HEIGHT	900	900	950	950
G MAXIMUM CUTTER HEIGHT	5000	5000	5000	5000
H REAR OVERHANG	2543	2543	2680	2680
FRONT WHEELS	445/45 R19,5	445/45 R19,5	445/45 R19,5	445/45 R19,5
BACK WHEELS	425/40 B17	425/40 B17	445/45 B19,5	445/45 B19,5
VOLUME (m ³)	14,5	16	17	19
WEIGHT (Kg.)	12550	10640	12700	13000

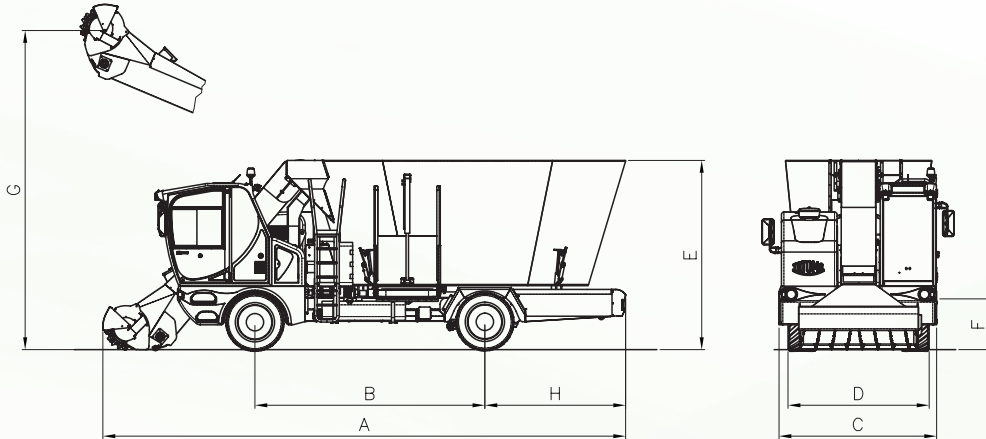

“DUPLOMIX” MVS-DC REAR UNLOADING BELT

DIMENSIONS (mm)	MVS-145	MVS-160	MVS-17	MVS-19
A OVERALL LENGTH	9040	8960	8850	8850
B DISTANCE BETWEEN AXLES	3131	3131	3720	3720
C MAXIMUM WIDTH	2550	2550	2550	2550
D OUTER WHEEL WIDTH	2330	2330	2330	2330
E OVERALL HEIGHT	2500	2650	3080	3250
F UNLOADING HEIGHT	900	900	950	950
G MAXIMUM CUTTER HEIGHT	5000	5000	5000	5000
H REAR OVERHANG	2543	2543	2680	2680
FRONT WHEELS	445/45 R19,5	445/45 R19,5	445/45 R19,5	445/45 R19,5
BACK WHEELS	425/40 B17	425/40 B17	445/45 B19,5	445/45 B19,5
VOLUME (m ³)	14,5	16	17	19
WEIGHT (Kg.)	10820	10900	10970	11270

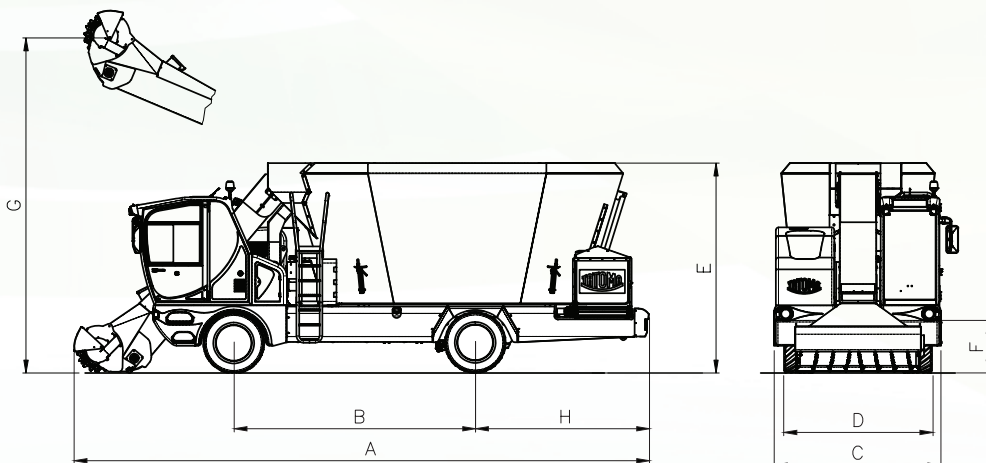

TATOMA



DISTRIBUTOR

Pol. Industrial Paüles, parc. 53-55 - 22400 Monzón (Huesca), SPAIN
 Tel.: (+34) 974 401 336 - Fax: (+34) 974 400 670
 inmosa@grupotatoma.com - www.grupotatoma.com

EDITION: SEPTEMBER 2013